

Small orifices in air relief valves – the search for an alternative design

Water pipeline designers need to take steps to ensure any air which accumulates can be vented to the atmosphere. Initial designs for air relief valves have been hampered by the need for small orifices. This article looks at the challenges for air relief valves and reviews a recently developed alternative technology.

By Mr. Umit Ozdogan, Yanki Ltd.

Air in water pipelines can have a huge negative effect on the safety and efficiency of the pipelines. The initial designs for air valves included two major functions. One is to intake air into the pipeline to avoid creation of excessive vacuum. The second is to relieve air during filling of the pipeline.

It was then discovered that there may still be some air accumulated at peak pipeline locations even when they are de-aerated during filling, as water contains a certain percentage of dissolved air which is continuously released from the water during operation. Mechanical equipment (mainly pumps) can also be another source of air for a full pipeline. Whatever the actual reason, there can be no doubt that air is collected even on a running pipeline, which must be relieved from the pipeline automatically, while the pipeline is pressurised and running.

Air valves with large orifices are unable to provide such relief because the ball can be held stuck in the closed position due to the force created by the differential pressure. Thus the ball does not fall down in the absence of water swept down by air

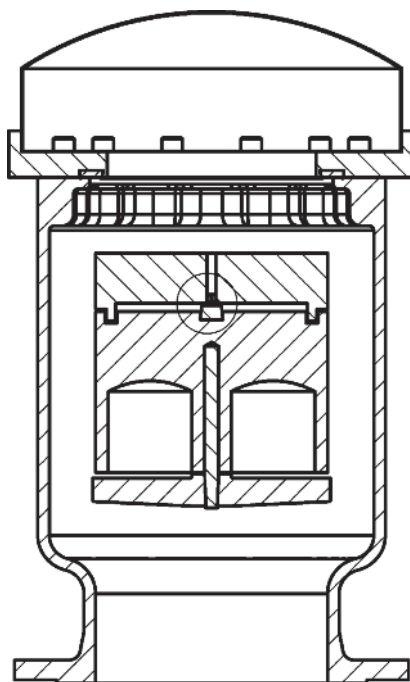
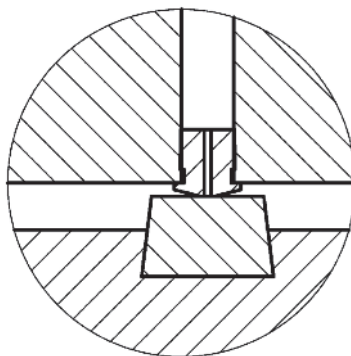

Fig. 1: Older air relief valve design with tiny orifice



accumulation.

Engineers studied this topic and calculated the force holding the ball, $\text{Force} = \text{diffPressure} \times \text{orifice area}$. In principle, if the ball is heavier than this force, it can fall down and relieve the air even under pressure. This theory works in practice and is still in use by almost all well-known air valve manufacturers. But main headache is that, due to the given calculation, this orifice has to be a very tiny hole. Typically it varies between 1mm to 3mm, depending on design and size of air valve (see Figure 1).

This limitation frequently causes the following problems:

- A small hole is easily blocked by small particles, which are always present in pipelines
- Particles coming between the seal and orifice block the closing
- In order to seal properly, due to low force from the float, a soft rubber material is used for sealing. The sharp edge of the orifice usually leaves a mark in the seal and, after a period of operation, leakage starts when the mark is missed by the guide system
- Guide system needs to be very accurate, as sealing is hard to achieve
- Higher pressure means either smaller hole or bigger valve housing
- Smaller valves means smaller holes.

Alternative technology

As all manufacturers use a similar tiny orifice hole, it is a logical question to ask whether there is an alternative way to achieve the goal of relieving the air under pressure. Now there is a new alternative design. This design also uses a float to sense the presence of air but this float does not shut off a tiny orifice. Instead the float operates a special ceramic cock valve system (see Figures 2 and 3). The advantages of this system can be listed shortly as follows:

- Due to low operation torques, the system is very reliable
- Ceramic discs provide drop tight sealing under all conditions, and due to sliding operation, they will not be damaged by particles
- Even though the system cannot be damaged by particles, the air (and water, if it should reach that position) is filtered away before reaching the sealing system
- There is no resilient element, which could cause a problem after a period of operation
- Orifice position is visible externally
- As required torque does not increase

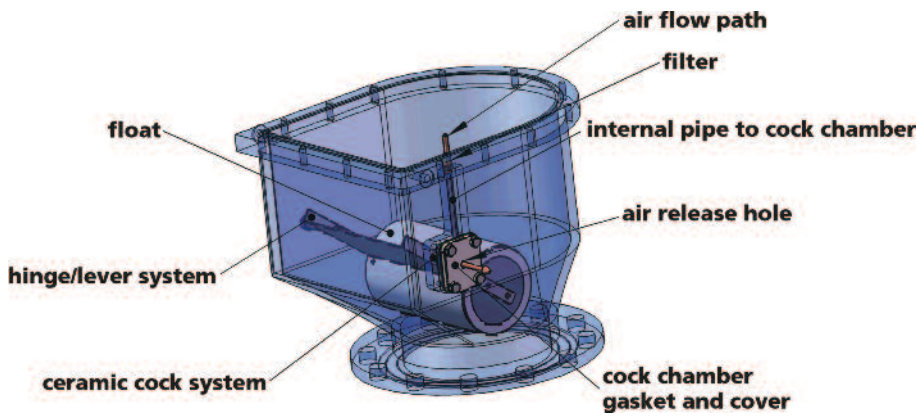

Fig. 2: The QuadFlow Air Valve

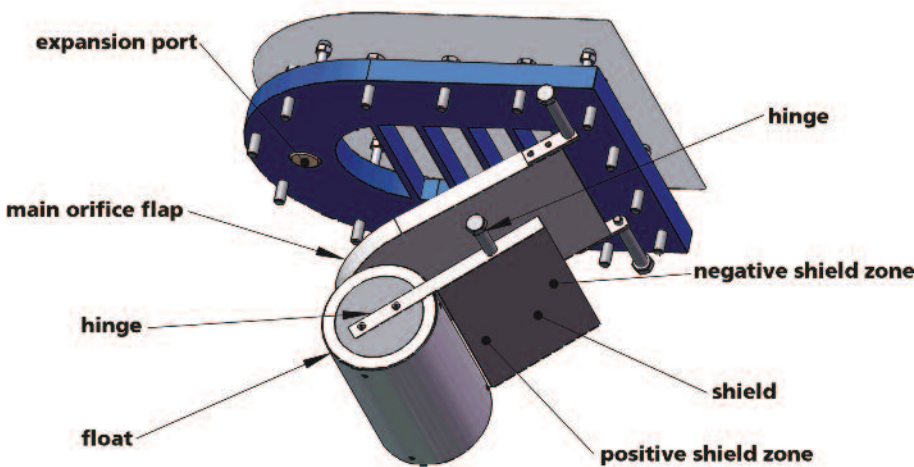

Fig. 3: Internal view from underneath

some problems due to premature closing and then the newer designs allowed much higher flow rates as a solution. It was discovered that, once the valve closes rapidly during an excessive flow rate, it creates very high pressure surges which can damage the pipeline.

The solution applied by some manufacturers is to use a secondary cylinder system with a separate orifice, so that air is discharged slowly and the pressurised air acts like an air cushion, which also allows a smooth closure. In the QuadFlow design, there is no extra cylinder or similar part. Once the flow rate exceeds the set level, the main orifice flap closes but the small orifice remains open. Due to the relatively large diameter and increased pressure, the air discharged is enough to eliminate the need for any extra orifice to serve as an anti-surge facility. In case there is a requirement for more flow, there is an optional diaphragm valve located on expansion port, using the ceramic cock system as pilot operator.

Another advantage of the design is the ability to set this anti-surge trigger flow rate. With the minimum rate there is no surge, while the maximum rate allows much higher flow but can cause some limited amount of surge. This feature is achieved by the specially designed shield, which changes the characteristics aerodynamically.

The producer and patent applicant of the design is Yanki Ltd., Turkey, which is represented world-wide by AVM Valves AS, Norway. For further information: www.avm.no or www.quadflow.com.tr.

much when the working pressure increases, the same housing can be used for higher pressures

- Ceramic pads are commercially available
- Although this application is new for an air valve, the technology has been used for many years
- The flow path is equal to a 6mm hole, which gives an excessive flow rate
- Due to very good flow rate, it also eliminates the need for a secondary anti-surge orifice plate
- As an option, the system can be used as a pilot operator; where an extra diaphragm valve can be operated to discharge an unlimited volume of air.

This system is used as a main part of the QuadFlow Air Valve design. The main orifice in the design is also unique, having a rectangular opening with some rib supports. This orifice is closed by a swing action flap

instead of a ball or cylinder. Despite this the flap is also floating, its main closure is supported by the same cylinder operating the ceramic cock.

The QuadFlow name is used in order to indicate four duties. The first three were listed above. The fourth function is called an anti-surge facility. Air valves in the past had

About the company:

The company manufactures speciality valves and air valves in Turkey for AVM Valves AS, Norway. The engineers of Yanki Ltd. are working for AVM Valves AS and are technically responsible for the valve production of AVM Valves AS, including after sales service etc. AVM Valves AS is a company operating in the production and world-wide sales of valves and other pipeline equipment.

About the author:

Mr. Umit Ozdogan is a mechanical engineer specialised in valve design and manufacturing.



After his studies in other valve companies, he set up his own factory with partners in 1996. After 10 years of continuous manufacturing, he decided to leave and start a new company of his own, Yanki Ltd., whilst at the same time he was appointed as Technical Manager of AVM Valves AS, Norway.