



Piston Adjustable Pressure Reducing/ Flow Control Valve - PN 10-25

Art. K41-
/10-25

Description:

The piston pressure reducing/flow control valve is an automatic control valve, which can stabilise outlet flow at a set rate. When inlet flow is less than the set point, the main valve will open. At the same time, the stability of the flow will not be affected by variation in inlet flow and pressure.

The pilot gauge passes differential pressure signal to flow limiting pilot valve. The outlet flow reaches set point as the flow limiting pilot valve modulates. The downstream pressure can be controlled through the pressure reducing pilot valve.

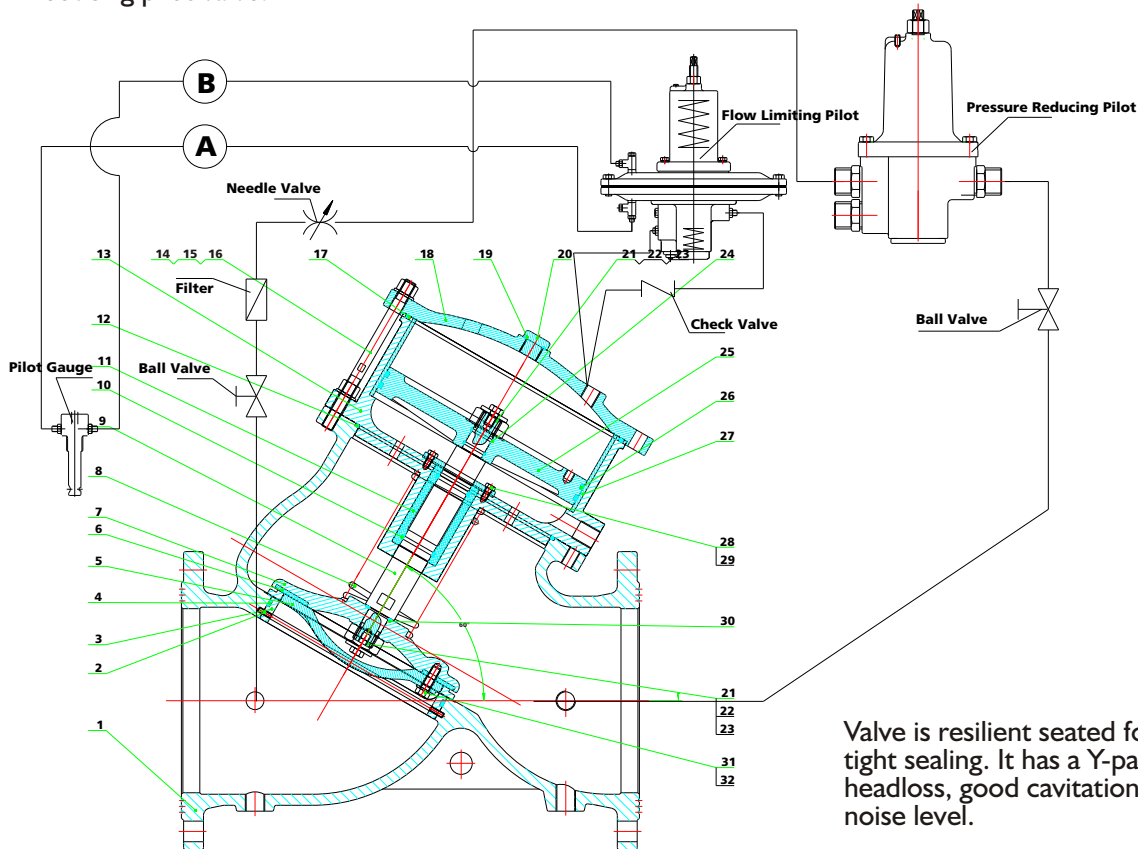

Valve is resilient seated for reliable and drop tight sealing. It has a Y-pattern shape for low headloss, good cavitation resistance and low noise level.

No.	Description	Material	Standard	BS Standard	DIN Standard
1	Body	Ductile Iron	GGG 50	2789-73 Gr. 500/7	1693 GGG-50
2	Lock Bolt				
3	Valve Seat	Copper Alloy	ZCuAl9Mn2	BS 1400 AB1	
4	O-ring	NBR			
5	Push Board	Ductile Iron	GGG 50	2789-73 Gr. 500/7	1693 GGG-50
6	Seal Gasket	PTFE			
7	Disc	Ductile Iron	GGG 50	2789-73 Gr. 500/7	1693 GGG-50
8	Spring		60Si2Mn		
9	Stem	Stainless Steel	1Cr18Ni9Ti / 316SS		
10	O-ring	NBR			
11	Guide Cover	Polyoxymethylene			
12	O-ring	NBR			
13	Cylinder	Ductile Iron	GGG 50	2789-73 Gr. 500/7	1693 GGG-50
14	Bolt Shaft	Stainless Steel	1Cr18Ni9Ti / 316SS		
15	Hex Nut	Stainless Steel	1Cr18Ni9Ti / 316SS		
16	Washer	Stainless Steel	1Cr18Ni9Ti / 316SS		
17	O-ring	NBR			
18	Cylinder Cover	Ductile Iron	GGG 50	2789-73 Gr. 500/7	1693 GGG-50
19	O-ring	NBR			
20	Hex Head Plug		H62		
21	Hex Nut	Stainless Steel	1Cr18Ni9Ti		
22	Hex Head Bolt				
23	Gasket	Stainless Steel	H62		
24	O-ring	NBR			
25	Piston	Copper Alloy	ZCuAl9Mn2		
26	O-ring	NBR			
27	Cylinder Bush	Copper Alloy	ZCuAl9Mn2		
28	Hex Head Bolt				
29	Press Board		H62		
30	O-ring	NBR			
31	Hex Head Bolt				
32	Flat Gasket				

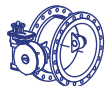



Piston Adjustable Pressure Reducing/ Flow Control Valve - PN 10-25

Art. K41-
/10-25

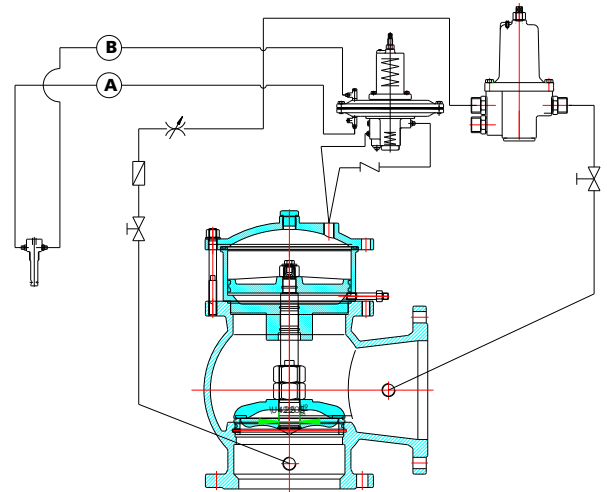
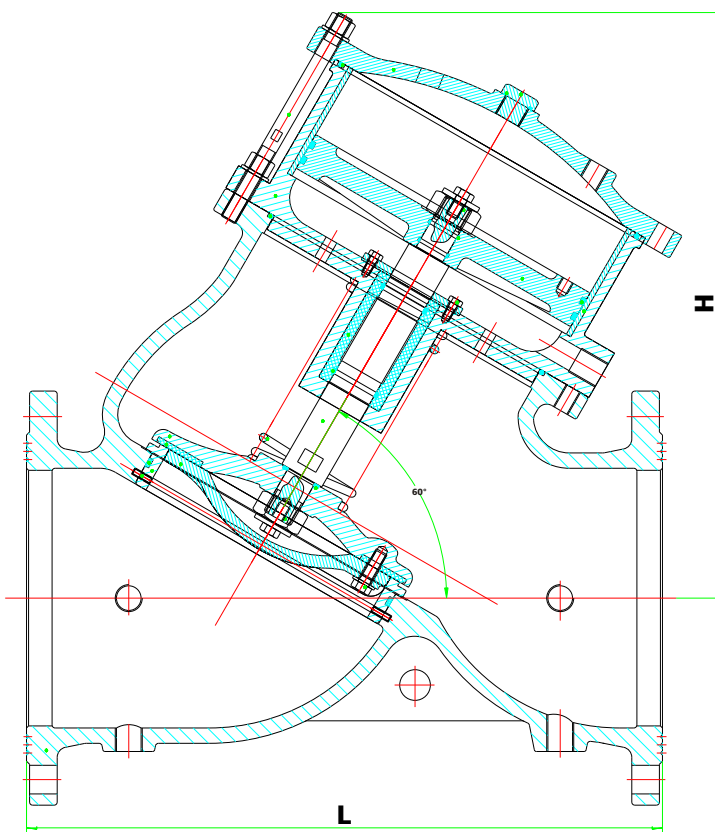

Angle Pattern DN 40-300

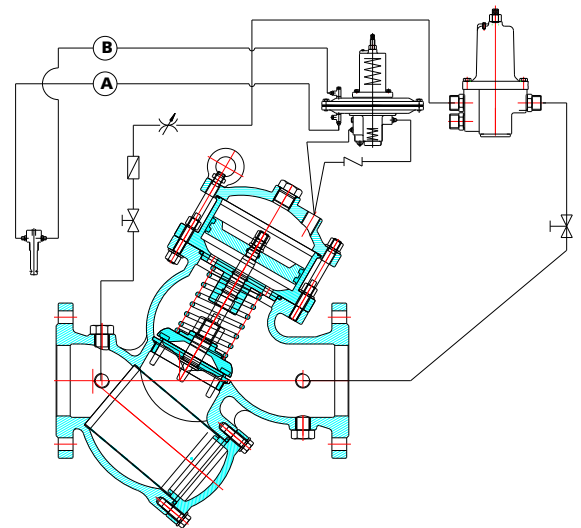

Filter Version DN 40-300

DN	L	H
40	280	245
50	280	245
65	305	245
80	325	250
100	375	260
150	440	350
200	600	477
250	622	510
300	810	658
350	940	708
400	948	818
450	1050	900
500	1100	950
600	1295	1125
700	1448	1260
800	1590	1408
900	1448	1600
1000	2200	1850
1200	2600	2100

